



**Technical Service
Information Bulletin**

September 22, 2006

Title:

**FRONT LICENSE PLATE MOUNTING
BRACKET & LICENSE PLATE
INSTALLATION**

Models:

'07 LS 460

PRE-DELIVERY SERVICE
PD069-06
REVISED

TSIB REVISION NOTICE:

- November 10, 2006: Step 1 has been updated, and an illustration has been added. Previous versions of this TSIB should be discarded.

Introduction The front license plate mounting bracket and two self-tapping screws for the 2007 model year LS 460 are placed in the luggage compartment of the vehicle at the assembly plant. For states that require a front license plate, install the bracket and bolts on the bumper cover during Pre-Delivery Service (PDS) according to the following procedures.

- Applicable Vehicles**
- 2007 model year **LS 460** vehicles.

Warranty Information

OP CODE	DESCRIPTION	TIME	OFF	T1	T2
N/A	Not Applicable to Warranty	—	—	—	—



Installation Procedure

1. Align holes "A" of the mounting bracket with the LOWER set of dimples on the front bumper cover. Mark the location of holes "B" on the front bumper cover.

NOTE:

- There are two sets of dimples on the front bumper cover. Use the LOWER set of dimples.
- Holes "A" are used to install the mounting bracket to the bumper cover.
- Holes "B" are used for installation of the front license plate to the mounting bracket.

2. Drill two relief holes with a diameter of 11 mm (0.43 in.) at the marks on the front bumper cover (holes "B" location) to prevent the license plate retaining bolt ends from contacting the cover.

NOTE:

Do NOT drill into the dimples on the front bumper cover.

3. Install the mounting bracket to the front bumper cover at holes "A" using the two supplied self-tapping screws.

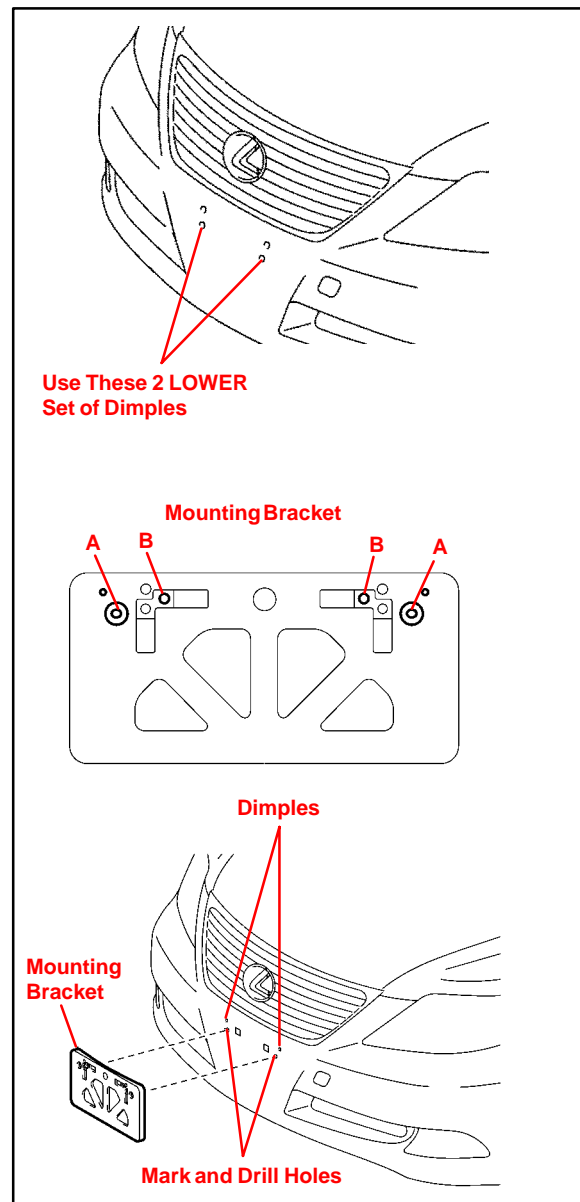

Installation Procedure
(Continued)

4. Install the front license plate to the mounting bracket at holes “B” using two bolts of the size listed below.

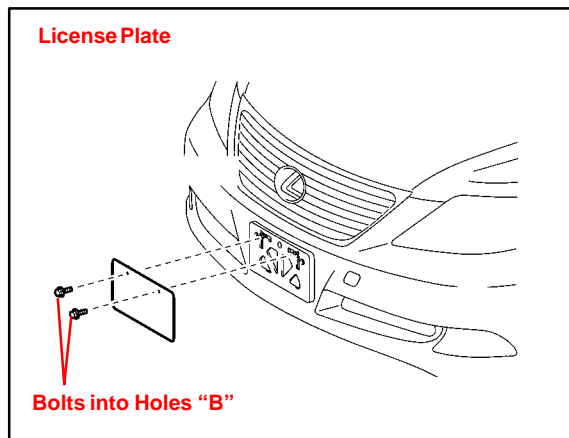

Use non-corroding bolts with the following dimensions to install the front license plate:

Nominal Length: 15.0 mm (0.59 in.)

Diameter: 6.0 mm (0.24 in.)

